

Model: NC6

Parts Book & Manual

Made In Japan

#1 Rated Horizontal Axis Walking Foot in the World



NC Carpet Binding & Equipment
858 Summer Avenue
Newark, NJ 07104 USA

973-481-3500 www.nccarpet.com

CONTENTS

1. MAIN PARTS NAMES	1
2. SPECIFICATIONS	1
3. WORK TABLE AND MOTOR	2
4. INSTALLATION	3
4-1. Installing the rubber hinge and the corner rubber	3
4-2. Installing the oil pan	3
4-3. Installing the machine head	3
4-4. Installing the spool pin	4
4-5. Installing the knee/litter assembly	4
4-6. Installing the belt	5
4-7. Installing the bobbin winder	5
4-8. Installing the belt guard (L)	6
4-9. Installing the thread stand	6
4-10. Lubrication	7
4-11. Checking the machine pulley rotating direction	8
5. PREPARATION BEFORE SEWING	9
5-1. Installing the needle	9
5-2. Removing the bobbin case	9
5-3. Winding the lower thread	10
5-4. Installing the bobbin case	10
5-5. Threading the upper thread	11
5-6. Adjusting the stitch length	11
6. SEWING	12
6-1. Sewing	12
6-2. Backtacking	12
7. THREAD TENSION	13
7-1. Adjusting the thread tension	13
7-2. Adjusting the presser foot pressure	13
8. STANDARD ADJUSTMENTS	14
8-1. Adjusting the thread controller spring	14
8-2. Adjusting the height of the feed dog	15
8-3. Adjusting the feed dog position (longitudinal)	15
8-4. Adjusting the positions of the needle and needle hole of the feed dog	16
8-5. Adjusting the timing the needle with feed	17
8-6. Adjusting the height of the needle bar	17
8-7. Adjusting the timing between the needle and hook	18
8-8. Adjusting the clearance between rotary hook and opener (thread release finger)	19
8-9. Adjusting the clearance between feed forked connection and feed fork collar	20
8-10. Adjusting the height of the presser feet	20
8-11. Adjusting the presser foot movement amount	21
8-12. Adjusting the timing of the vibrating presser foot	22
8-13. Adjusting the feed regulator	23
9. SAFETY CLUTCH MECHANISM	24

1. MAIN PARTS NAMES
2. SPECIFICATIONS

1. MAIN PARTS NAMES

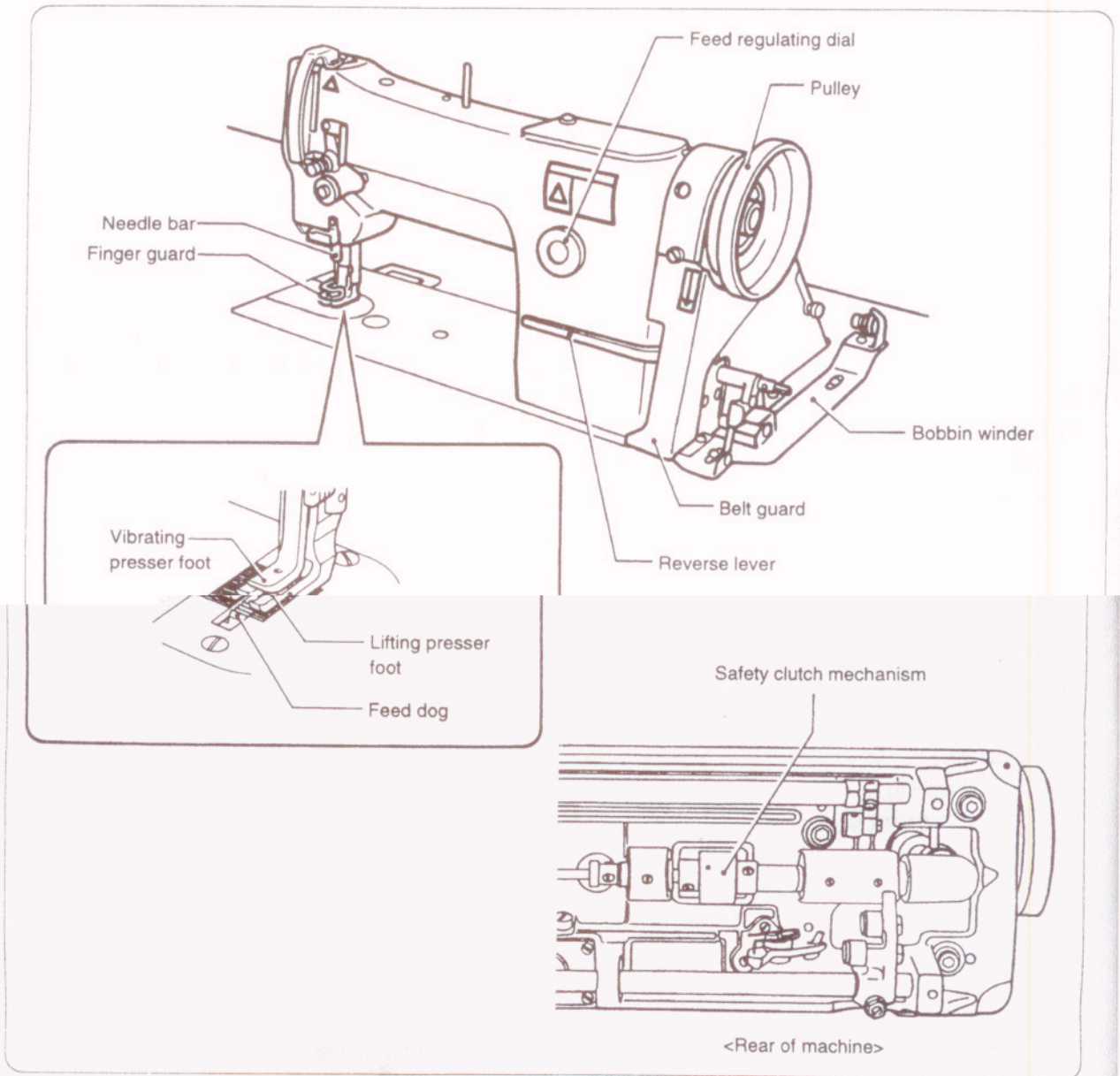







2. SPECIFICATIONS

Use	Medium-thick materials - very thick materials	
Sewing speed	2,200 spm	
Presser foot height	Presser bar lifter	8.5 mm
	knee lifter	14 mm
Max. stitch length	10 mm	
Feed dog height	1 mm	
Needles	DP X 17	

4. INSTALLATION

⚠ CAUTION

- 
 - The sewing machine should only be installed by a qualified technician.
- 
 - Ask your SEIKO dealer or a qualified electrician for any electrical work that may need to be done.
- 
 - The sewing machine weights more than 29 kg. The installation should be carried out by two or more people.
- 
 - Do not connect the power cord until installation is complete, otherwise the machine will operate if the treadle is pressed by mistake, which could result in injury.
- 
 - Be sure to connect the ground. If the ground connection is not secure, serious electric shocks will result.
- 
 - Install the belt guard to the machine head.

4-1. Installing the rubber hinge and the corner rubber

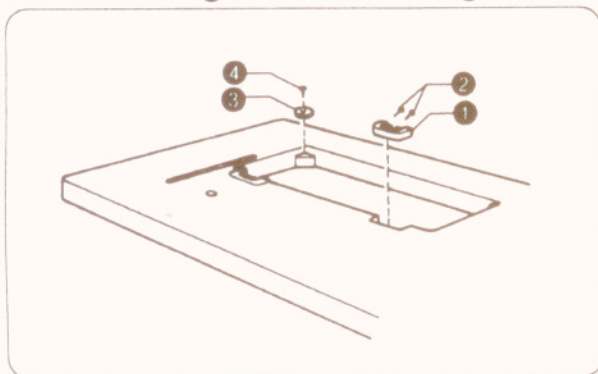

1. Install the rubber hinge **1** on the table with nails **2**. (Two places)
2. Install the corner rubber **3** at the four corners of the table with nails **1**.

4-2. Installing the oil pan

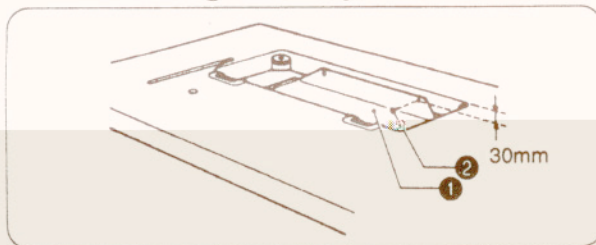

Fit oil pan **1** into the opening in the table, and secure it with 4 nails **2**.

(Refer to the work table processing diagram on page 2.)

4-3. Installing the machine head

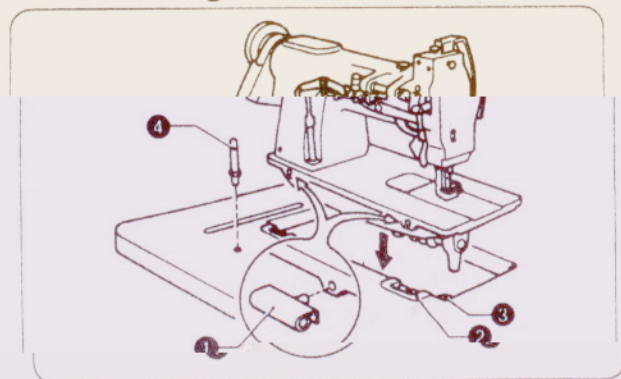

1. Insert the two bed hinge connections **1** into the holes in the machine bed.
2. Fit the bed hinge connection **1** to the rubber hinge **2** and then place the machine head onto the corner rubber **3**.
3. Tap the head rest **4** into the table hole.

NOTE: Tap the head rest securely into the table hole. If the head rest is not pushed in as far as it will go, the machine head will not be sufficiently stable when it is tilted back.

4-4. Installing the spool pin

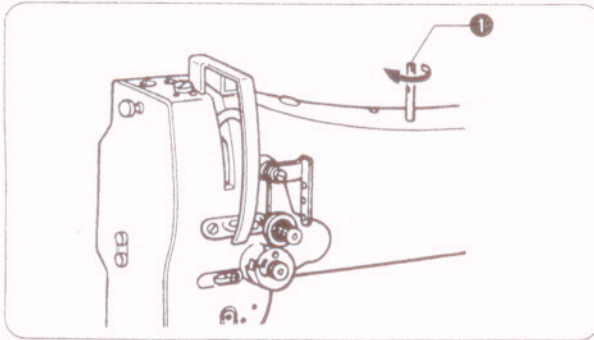

Insert the spool pin **1** into the installation hole, and screw it in tightly.

4-5. Installing the knee lifter assembly

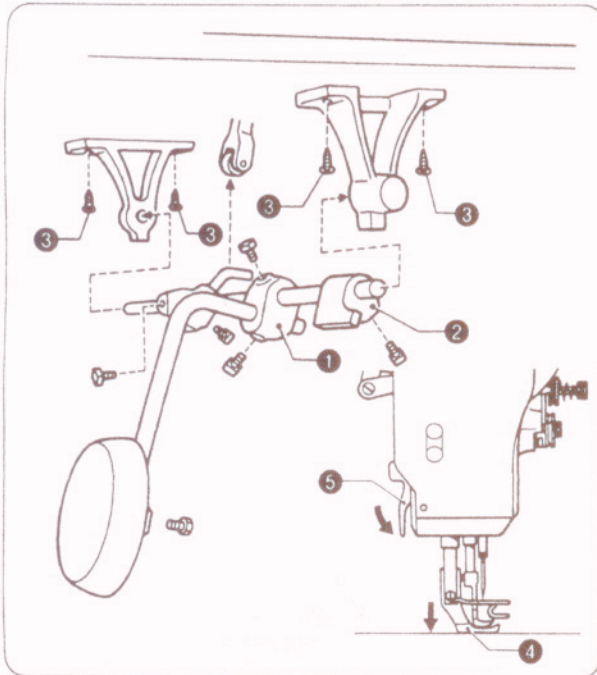

1. Assemble the knee lifter assembly **1** as shown in the illustration.

NOTE: Make sure that the knee lifter stopper **2** is facing in the correct direction.

2. Install the knee lifter assembly **1** on the back of the table with 4 screws **3**. (Refer to the work table processing diagram on page 2.)
3. Adjust the knee lifter.
 - 1) Lower the presser foot **4** by using the presser bar lifter **5**.

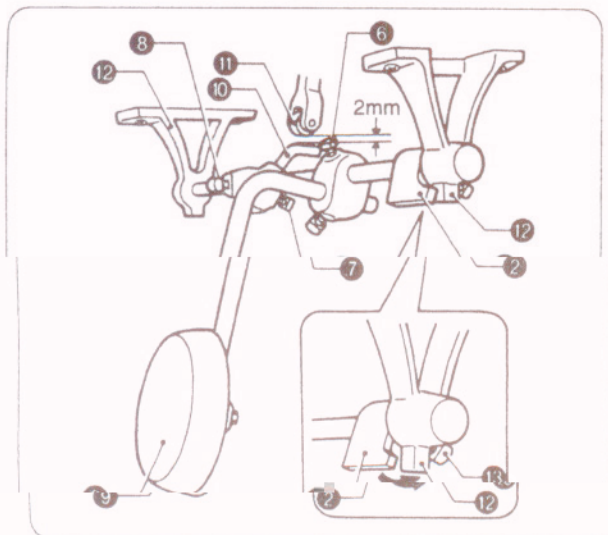

- 2) Loosen bolts **6**, **7** and **8**.
- 3) Adjust the position of the thrusting bar complete **10** so that the clearance between its curved section and the very bottom of the roller **11** is approximately 2 mm when the knee pad **9** is at the stop position.
- 4) Securely tighten bolts **6**, **7** and **8**.
- 5) Press the knee pad **9** to raise the presser foot **4** by 14 mm; then move the knee lifter stopper **2** in the direction of the arrow so that it is against the installation bracket projection **12**, securely tighten the bolt **13**.

4-6. Installing the belt

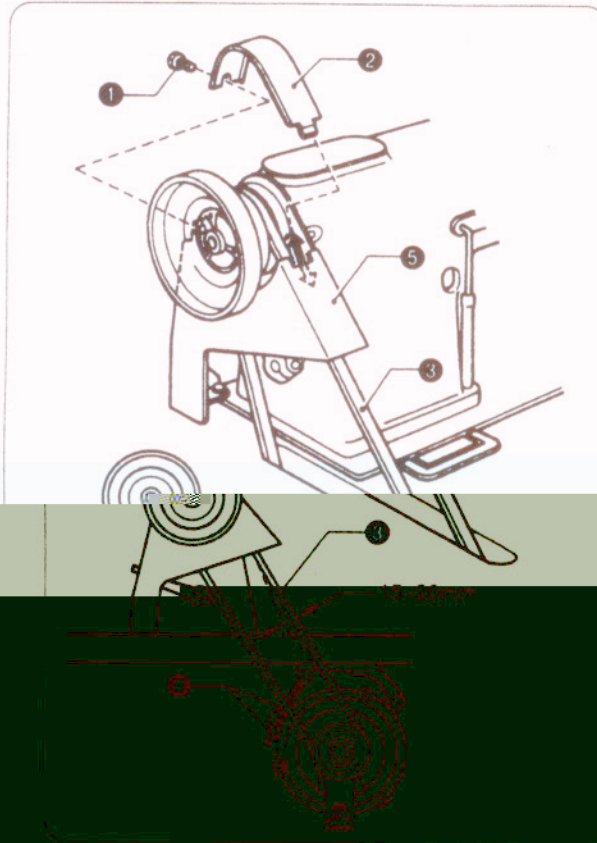

1. Remove the screw ① and remove the belt guard upper cover ②.
2. Tilt back the machine head, and then place the belt ③ onto the motor pulley and the machine pulley.
3. Turn the nut ④ to adjust so that there is 15-20 mm of deflection in the belt ③ when it is pressed with a finger with a force of 9.8 N (1 kgf).
4. Insert the belt guard upper cover ② into the belt guard ⑤ from above the pulley, and then tighten it with the screw ①.

4-7. Installing the bobbin winder

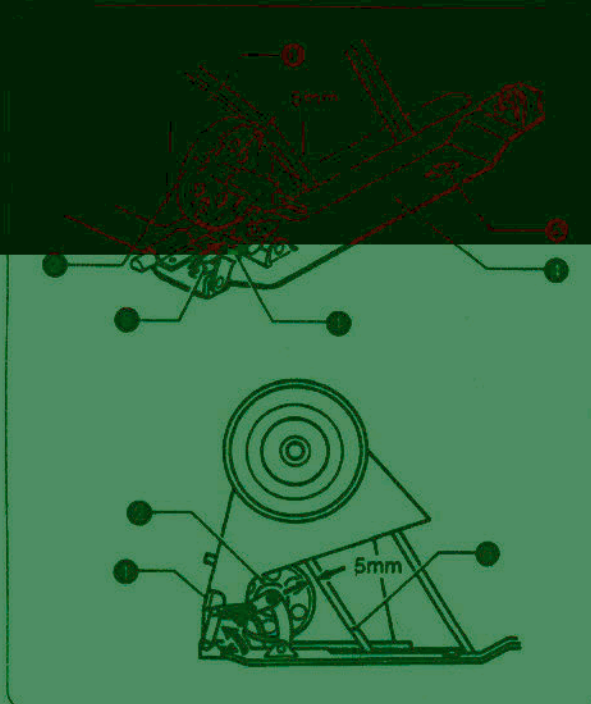

1. Push down the bobbin set lever ① as far as it will go.
2. Place the bobbin winder pulley ② so that it touches the belt ③ by approximately 2mm, and then place the bobbin winder ④ so that it is parallel with the belt hole in the work table.
3. Install the bobbin winder ④ to the screw ⑤ and fit in the two screws ⑥.
4. Pull the bobbin set lever ① back and check that there is approximately 5 mm of clearance between the bobbin winder pulley ② and the belt ③.

4-8. Installing the belt guard (L)

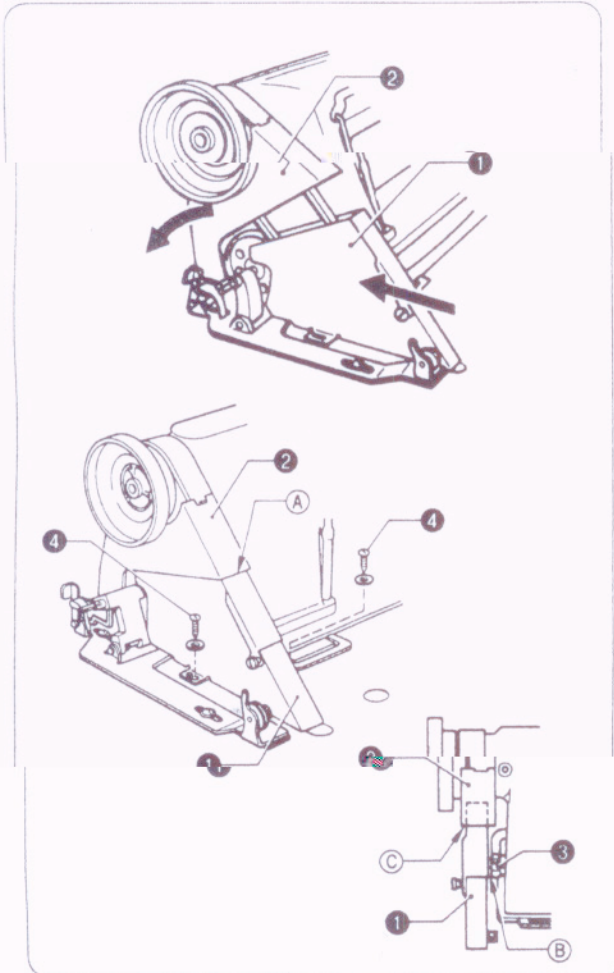

1. Tilt back the machine head, and then remove the V-belt from the motor pulley.
2. While tilting the machine forward, insert belt guard (L) ① into the belt guard ② from underneath, and let it rest there.
3. Place the V-belt back onto the pulley.
4. Install belt guard (L) ① with the two screws ④ so that there is no clearance between the belt guard ② and belt guard (L) ① (position A), and so that the reverse lever ③ and the belt guard ② are not touching (positions B and C).

4-9. Installing the thread stand

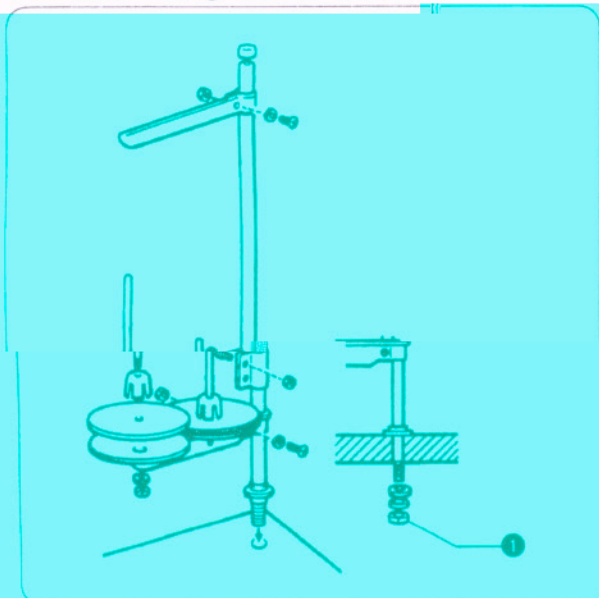



Assemble the thread stand as shown in the illustration, and then install it to the work table.

- * Securely tighten the nut ① so that the thread stand does not move.

4-10. Lubrication

CAUTION

-  Do not connect the power cord until lubrication has been completed, otherwise the machine may operate if the treadle is pressed by mistake, which could result in injury.
-  Be sure to wear protective goggles and gloves when handling the lubricating oil, so that no oil gets into your eyes or onto your skin, otherwise inflammation can result. Furthermore, do not drink the oil under any circumstances, as it can cause vomiting and diarrhoea. Keep the oil out of the reach of children.

- The sewing machine should always be lubricated and the oil supply replenished before it is used for the first time, and also after long periods of non-use.
- Use only the lubricating oil.

- Add 1-2 drops of oil in the places indicated by the arrows. Add oil to other sliding parts also, while being careful to avoid oil leaks.
- Oiling must be done at least twice daily in continuous use.

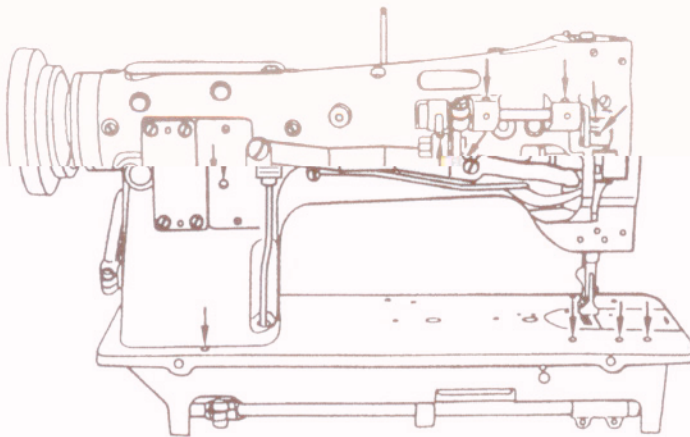
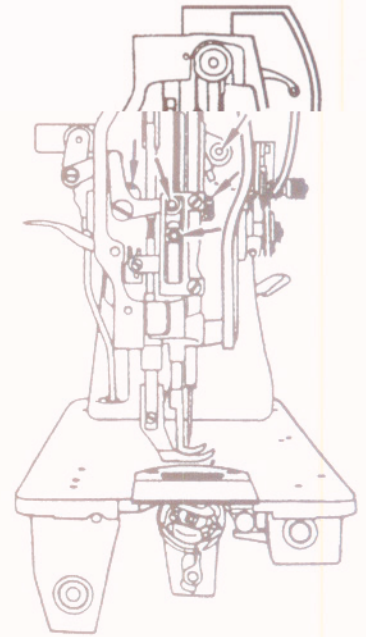
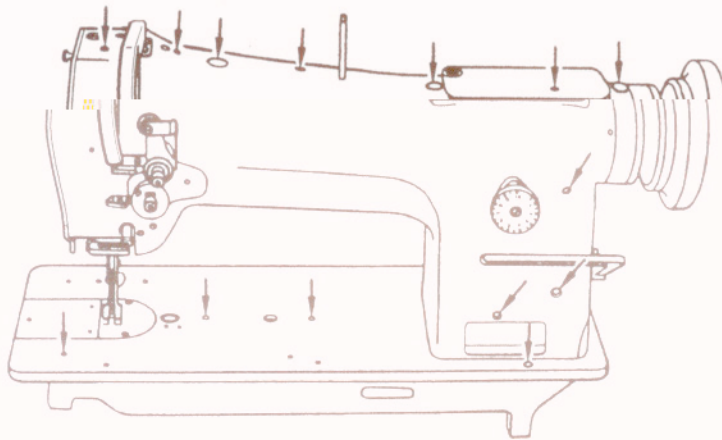

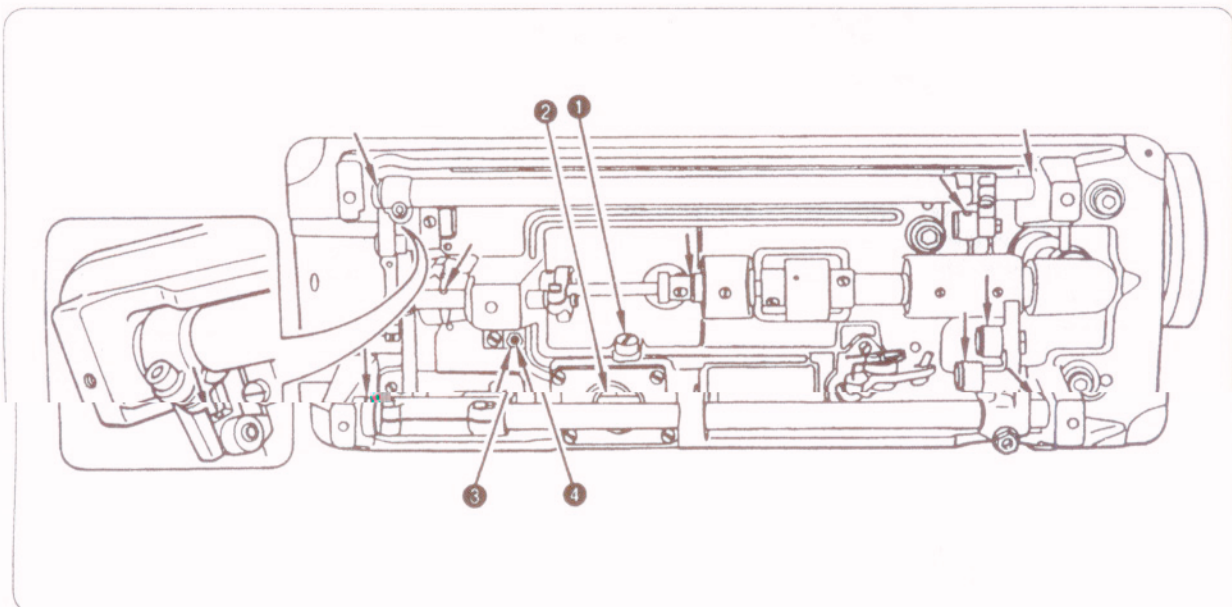

■ For oiling to hook

Remove the oil plug ① and pour oil until the oil surface reaches to the red line of the oil indicator ②. After pouring oil, tighten the oil plug ① securely.

■ Oiling adjustment to hook

Loosen the nut ③, adjust oiling by adjusting screw ④. To increase oil flow, loosen the adjusting screw ④, to decrease oil flow, tighten the screw ④. After oiling adjustments completed, tighten the nut ③ securely.

4-11. Checking the machine pulley rotating direction

⚠ CAUTION



- Do not touch any of the moving parts or place any objects against the machine while sewing, as this may result in personal injury or damage to the machine.

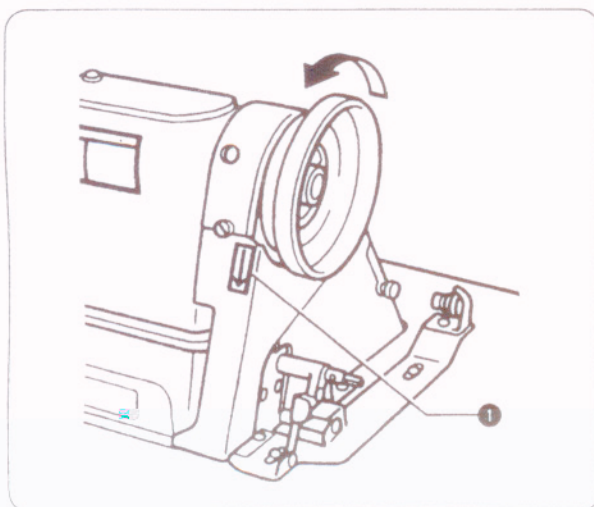

1. Insert the power cord plug into the wall outlet, and then turn on the power switch.
 2. Depress the treadle and check that the direction of rotation of the machine pulley matches the direction of the arrow ①.
- * If the direction of rotation is reversed, change the direction of rotation to the correct direction while referring to the instruction manual for the motor.

5. PREPARATION BEFORE SEWING

5-1. Installing the needle

CAUTION



- Turn off the power switch before installing the needle. The motor will keep turning even after the power is switched off as a result of the motor's inertia. Wait until the motor stops fully before starting work. The machine may operate if the treadle is pressed by mistake, which could result in injury.

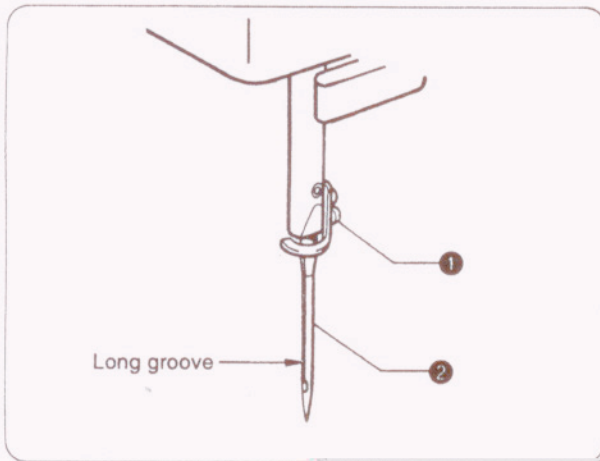

1. Turn the machine pulley toward you to move the needle bar to its highest position.
2. Loosen the screw ①.
3. Holding the needle ② with its long groove facing left, insert all the way into the needle bar.
4. Tighten the screw ①.

5-2. Removing the bobbin case

CAUTION



- Turn off the power supply before removing the bobbin case. The motor will keep turning even after the power is switched off as a result of the motor's inertia. Wait until the motor stops fully before starting work. The machine may operate if the treadle is pressed by mistake, which could result in injury.

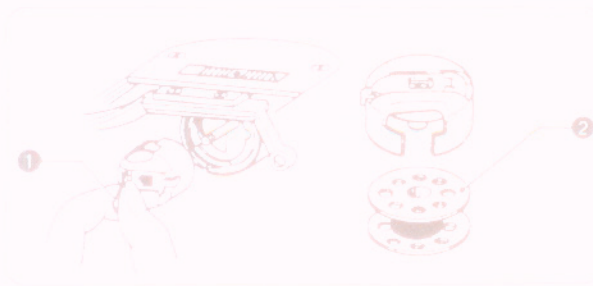

1. Open the bed slide.
2. Pull the latch ① of the bobbin case upward and then remove the bobbin case.
3. The bobbin ② will come out when the latch ① is released.

5-3. Winding the lower thread

! CAUTION

- Do not touch any of the moving parts or place any objects against the machine while winding the lower thread, as this may result in personal injury or damage to the machine.

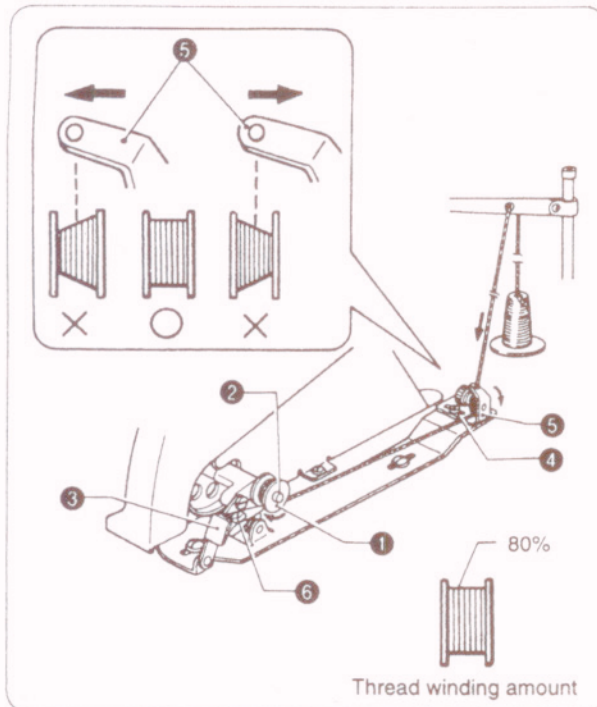

1. Turn on the power switch.
 2. Place the bobbin ① onto the bobbin winder shaft ②.
 3. Wind the thread several times around the bobbin ① in the direction indicated by the arrow.
 4. Push down the bobbin set lever ③.
 5. Raise the presser foot with the presser bar lifter.
 6. Depress the treadle. Lower thread winding will then start.
 7. Once winding of the lower thread is completed, the bobbin set lever ③ will return automatically.
- * If the thread cannot be wound on evenly, loosen the screw ④ and move the bobbin winder bracket ⑤ to the side where there is less thread.
 - * Turn the adjustment screw ⑥ to adjust the bobbin winding amount.
 - To increase the winding amount: Tighten the screw.
 - To decrease the winding amount: Loosen the screw.

Note: The amount of thread wound onto the bobbin should be a maximum of 80% of the bobbin capacity.

5-4. Installing the bobbin case

! CAUTION

- Turn off the power supply before installing the bobbin case. The motor will keep turning even after the power is switched off as a result of the motor's inertia. Wait until the motor stops fully before starting work. The machine may operate if the treadle is pressed by mistake, which could result in injury.

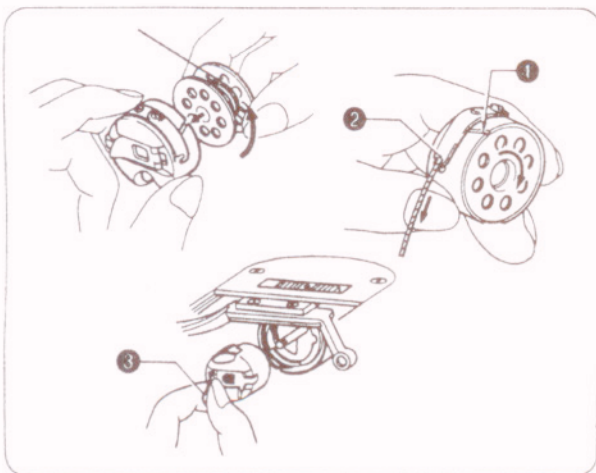

1. While holding the bobbin so that the thread winds to the right, insert the bobbin into the bobbin case.
2. Pass the thread through the slot ① and under the tension spring ②.
3. Pull the thread out through the hole in the end of the tension spring ②.
4. Check that the bobbin turns clockwise when the thread is pulled.
5. Hold the latch ③ on the bobbin case and insert the bobbin case into the rotary hook.
6. Close the bed slide.

5-5. Threading the upper thread

CAUTION



- Turn off the power switch before threading the upper thread. The motor will keep turning even after the power is switched off as a result of the motor's inertia. Wait until the motor stops fully before starting work. The machine may operate if the treadle is pressed by mistake, which could result in injury.

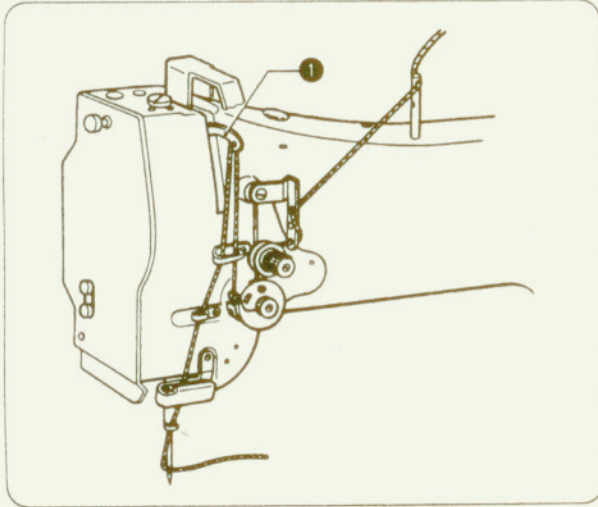

Turn the machine pulley and raise the thread take up lever ① before threading the upper thread. This will make threading easier and it will prevent the thread from coming out at the sewing start.

5-6. Adjusting the stitch length

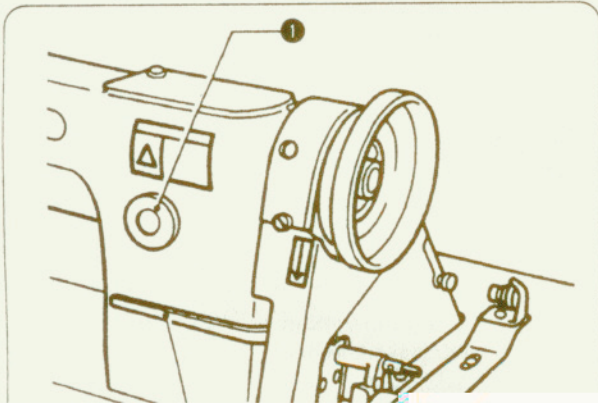



Stitch length can be set by turning the feed regulating dial ①.

Numeric figures on the dial ① show the stitch length in mm. The desired numeric figure on the dial ① should be set at just above, while depressing the revers lever ② slightly.

6. SEWING

CAUTION

-  • Attach all safety devices before using the sewing machine. If the machine is used without these devices attached, injury may result.
-  • Turn off the power switch at the following times. The motor will keep turning even after the power is switched off as a result of the motor's inertia. Wait until the motor stops fully before starting work. The machine may operate if the treadle is pressed by mistake, which could result in injury.
 - When threading the needle
 - When replacing the needle and bobbin
 - When not using the machine and when leaving the machine unattended
-  • Do not touch any of the moving parts or place any objects against the machine while sewing, as this may result personal injury or damage to the machine.

6-1. Sewing

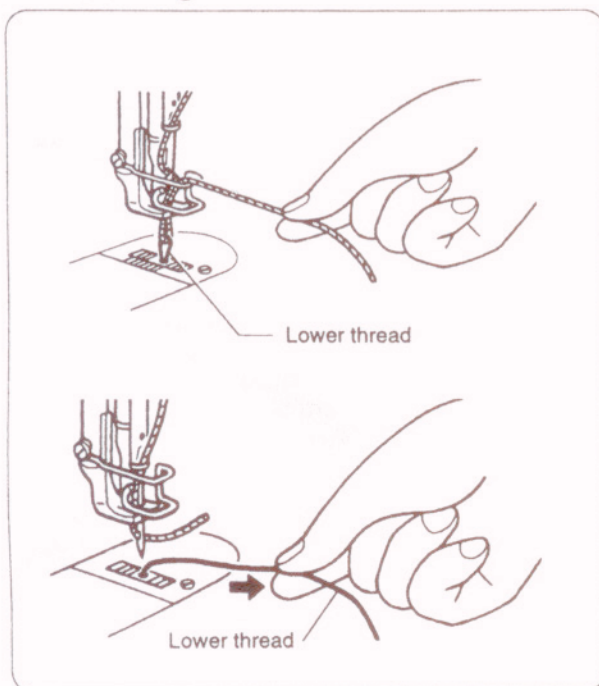

1. While holding the upper thread with your fingers, turn the machine pulley by hand toward you until the lower thread comes out onto the feed dog.
2. Pull the lower thread toward you and check that it pulls out smoothly.
3. Turn on the power switch.
4. Depress the treadle to start sewing.

6-2. Backtacking

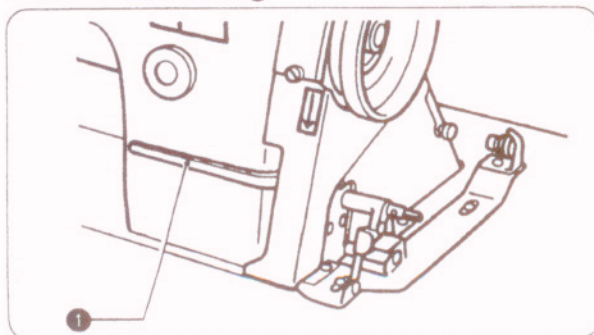

When the reverse lever **1** is pushed, the material feed direction will be reversed, and when it is returned to its original position, the feed direction will change back to normal.

7. THREAD TENSION

7-1. Adjusting the thread tension

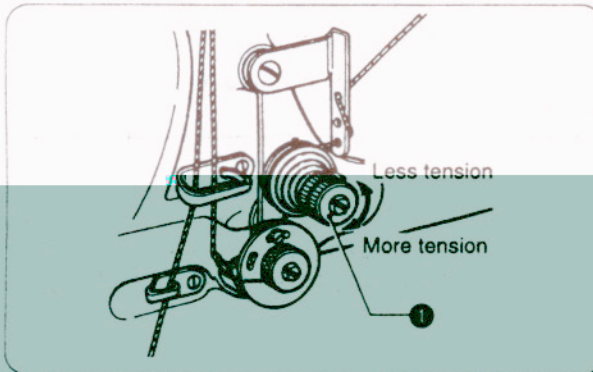
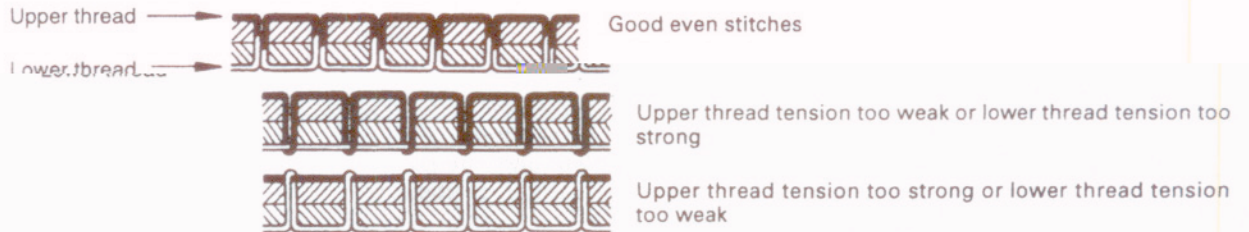

■ Upper thread tension

The tension of the upper thread is adjusted using the tension thumb nut ①.
To increase the tension of the upper thread, turn the tension thumb nut ① to the right. To decrease tension, turn the tension thumb nut ① to the left.

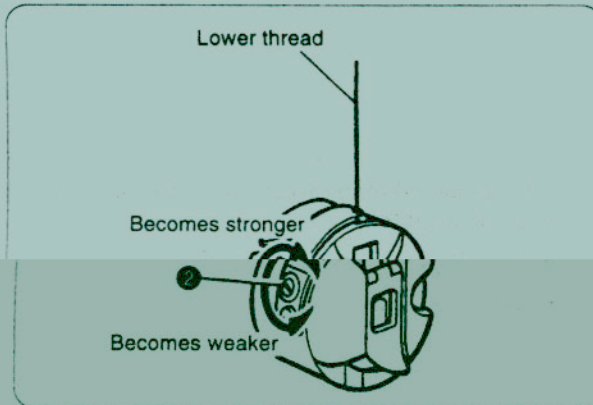

■ Lower thread tension

⚠ CAUTION



- Turn off the power switch before removing or inserting the bobbin case. The motor will keep turning even after the power is switched off as a result of the motor's inertia. Wait until the motor stops fully before starting work. The machine may operate if the needle is depressed by mistake, which could result in injury.

Adjust by turning the thread tension nut ② until the bobbin case will not drop by its own weight while the thread end coming out of the bobbin case is held.

7-2. Adjusting the presser foot pressure

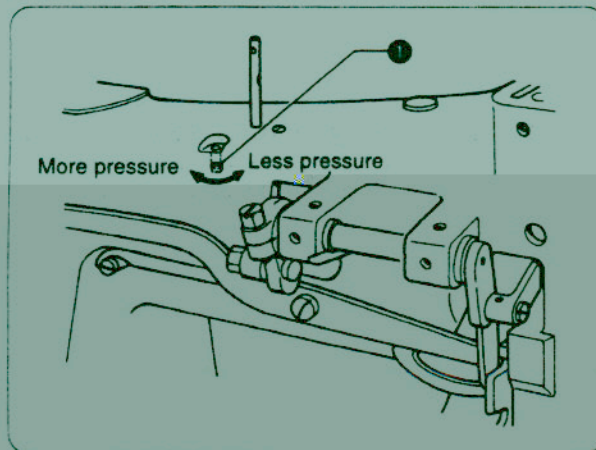

Adjust the presser foot pressure to lower as much as possible so that the presser foot can properly hold down material by turning the screw ①.

8. STANDARD ADJUSTMENTS

⚠ CAUTION

- ⊘ Maintenance and inspection of the sewing machine should only be carried out by qualified personnel.
- ⚠ Turn off the power switch and disconnect the power cord from the wall outlet at the following times, otherwise the machine may operate if the treadle is pressed by mistake, which could result in injury. However, the motor will keep turning even after the power is switched off as a result of the motor's inertia. Wait until the motor stops fully before starting work.
 - When carrying out inspection, adjustment and maintenance
 - When replacing consumable parts such as the rotary hook
- ⚠ If the power switch needs to be disconnected when carrying out some adjustment, be extremely careful to observe all safety precautions.

8-1. Adjusting the thread controller spring

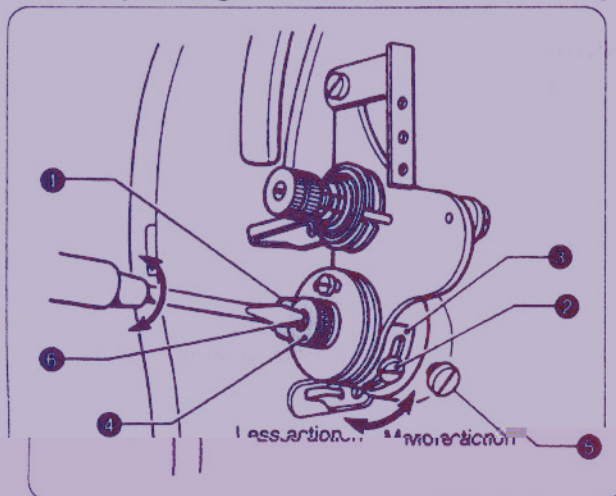

■ Operating range of spring

The standard operating range for spring ① is 5-10mm.

1. Loosen the screw ②, and then turn the thread controller spring stop ③ to adjust the operating range.
 - For more operating range, move the spring stop ③ to the right.
 - For less operating range, move the spring stop ③ to the left.
2. Tighten the screw ②.

■ Tension of the spring

The standard tension for spring ① is 0.39-0.78 N (40-80g).

1. Loosen the tension thumb nut ④ and screw ⑤.
2. Turn the tension stud ⑥ to adjust the tension.
 - To increase the spring tension, slightly turn the tension stud ⑥ counterclockwise.
 - To decrease the tension, turn the stud clockwise.
3. After adjustment, tighten the tension thumb nut ④ and screw ⑤.

8. STANDARD ADJUSTMENTS

8-2. Adjusting the height of the feed dog

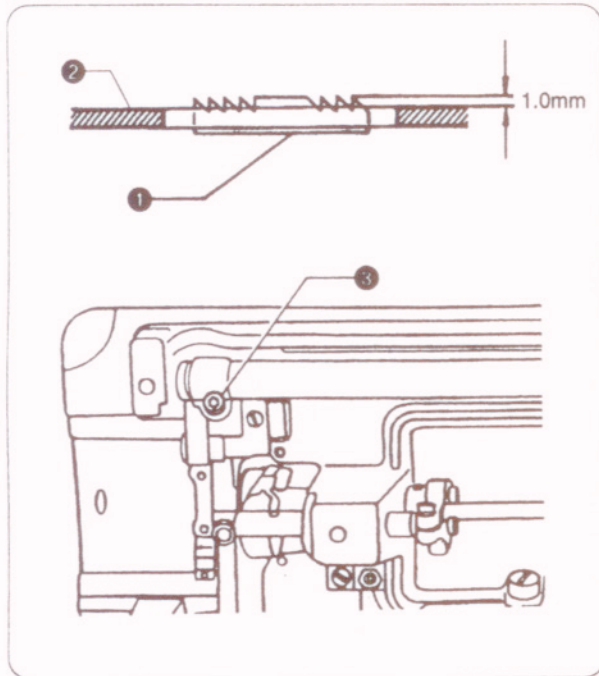

The maximum height of the feed dog ① from the surface of the needle plate ② is normally 1 mm. To adjust the height of the feed dog:

1. Tilt the machine head away from you. Turn the pulley to raise the feed dog ① to its highest position.
2. Loosen the screw ③.
3. Raise or lower the feed dog ① as necessary.
4. Tighten the screw ③.

8-3. Adjusting the feed dog position (longitudinal)

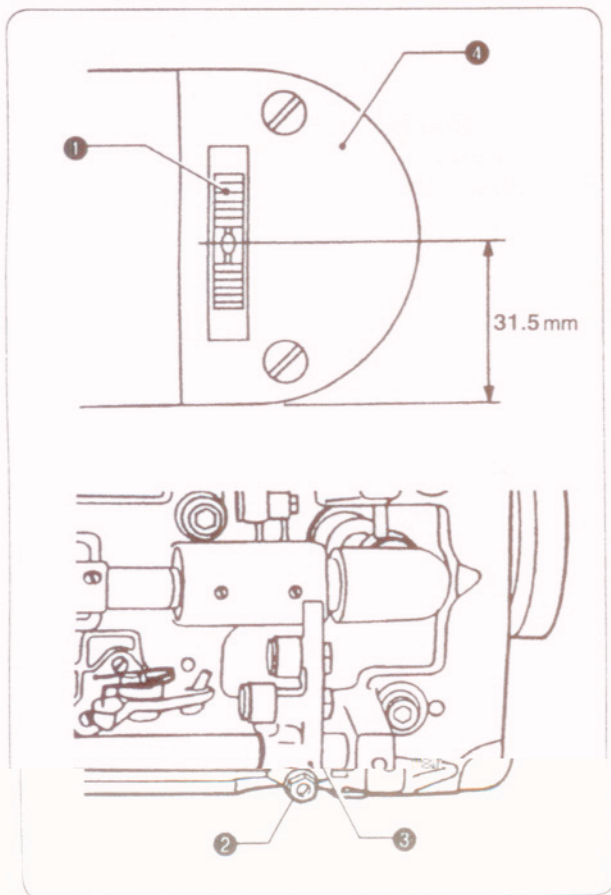

1. Change the feed amount to the smallest possible setting.
2. Turn the pulley to raise the feed dog ① to its highest position.
3. Tilt the machine head away from you.
4. Loosen the screw ②, and then move the feed rock shaft crank ③ to adjust so that there is a distance of 32.1 mm from the edge of the needle plate ④ to the center of the needle hole on the feed dog ①.
5. Securely tighten the screw ②.

8-4. Adjusting the Positions of the needle and needle hole of the feed dog

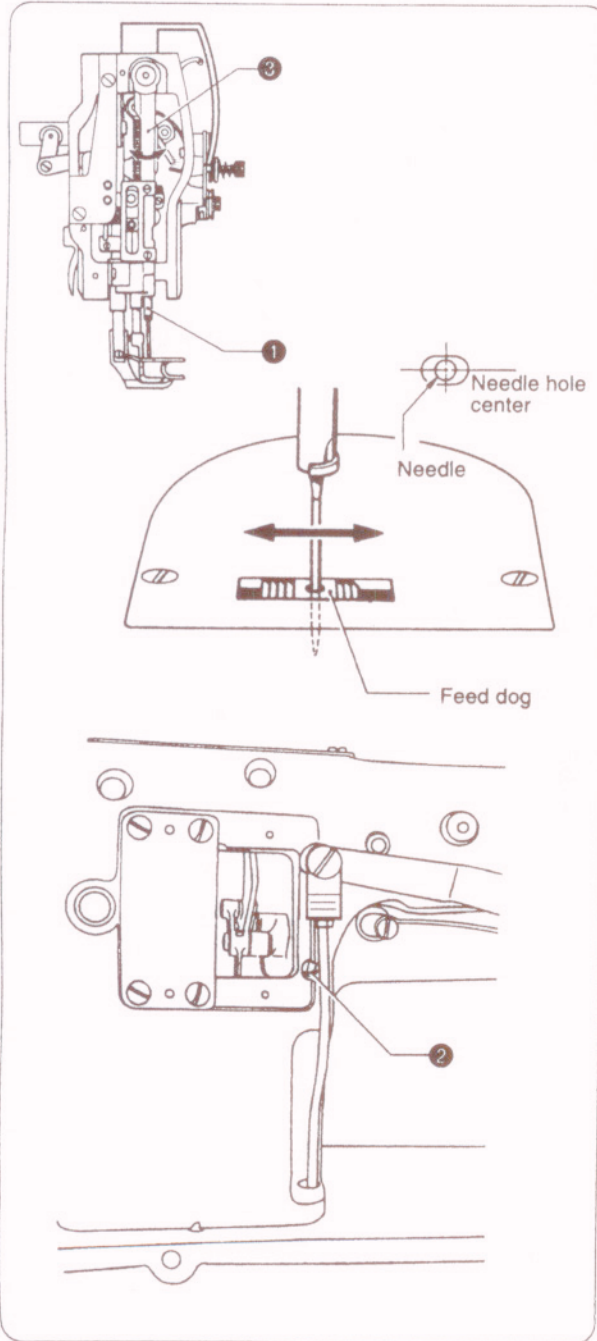

Turning the pulley to lower the needle bar **1** slowly, check whether the needle descends to the center of the needle hole of the feed dog or not.

If the needle does not enter into the center of the hole:

1. Remove the cover and loosen the screw **2** slightly.
2. Holding the needle bar rock frame **3**, move it as may be required to get the correct position to the feeder.
3. Tighten the screw **2** and close the cover.

8-5. Adjusting the timing the needle with feed

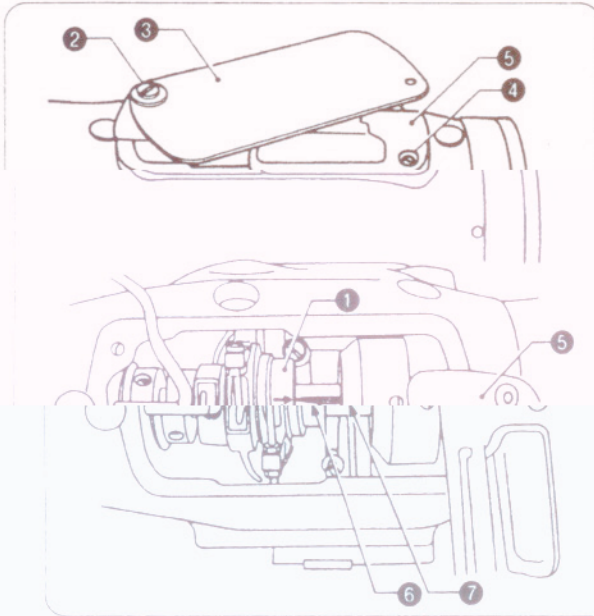

It is important that the timing relationship between the needle on its downward stroke and the feed dog movement is maintained at all times. When the scart of the needle on the downward stroke reaches the top surface of the feed dog, the feed dog movement must start. When adjustment is required, use the following procedure to change the position of cam ①.

1. Change the feed amount to the largest possible setting.
2. Loosen the screw ② for cover plate ③ and the screw ④ for oil reservoir ⑤, and then remove the cover plate ③ and the oil reservoir ⑤.
3. Normally put the arrow mark ⑥ of the cam ① on the vertical center of arm shaft.
4. Turn the machine pulley to the needle at 1 mm up from its lowest point.
5. And, pushing the reverse lever up and down, turn the cam ① and set this at the point both the needle and the feed dog rest.
6. After positioning completed, tighten the each screw securely.

8-6. Adjusting the height of the needle bar

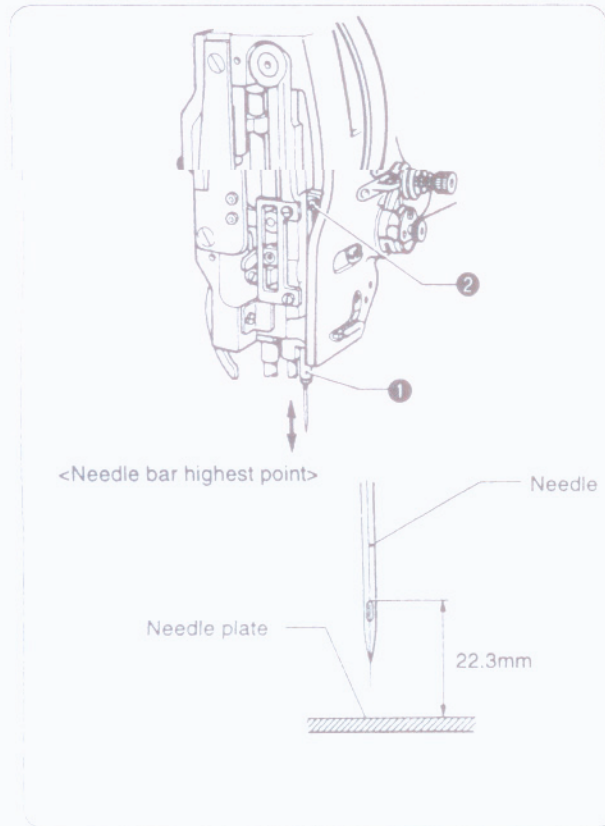

When the needle bar ① is at its highest point, normally the measurement between the surface of the needle plate and the upper end of the needle eye is 22.3mm.

1. Loosen the screw ② and move the setting position of the needle bar ① to get the correct position.
2. Tighten the screw ②.

8-7. Adjusting the timing between the needle and the hook

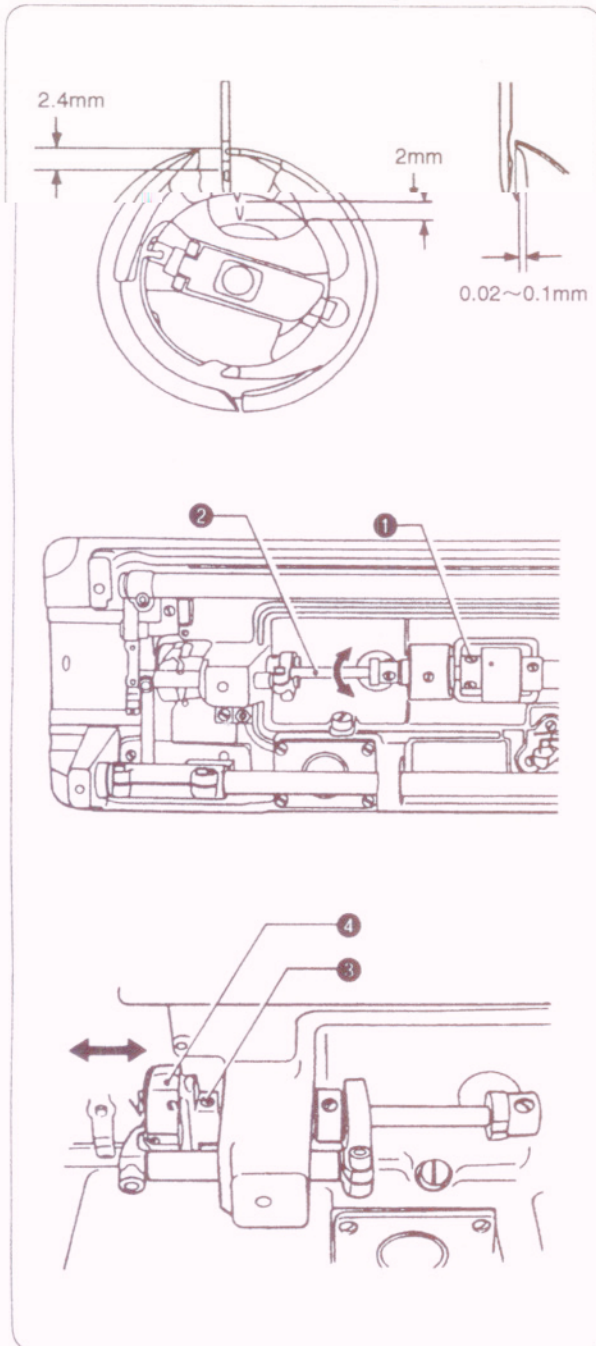

After setting the needle bar height, set stitch length to minimum, turn the machine pulley toward you until the needle bar reaches its lowest point. Continue turning and allow the needle bar to raise about 2mm while on its upward stroke. With needle bar in this position, the point of the sewing hook should be at the center of the needle, and normally, the measurement between the hook point, and the upper end of the needle eye should be 2.4mm, further the clearance between the hook point and the needle hollow should be about 0.02 to 0.1mm.

* If they are not measured as above, perform the adjustments below.

■ Adjusting the timing

1. Loosen the three set screws ①.
2. Turn the hook shaft ② to align the hook point with the center of the needle.
3. Tighten the three set screws ① and re-check the timing of the sewing hook.

■ Adjusting the clearance

1. Loosen the two screws ③ slightly.
2. Move the hook ④ to the right or to the left as may require.
 - * Please note one of the two screws ③ is placed on the V ditch of hook shaft. Therefore, keep the screw on V ditch during adjustment.
3. Tighten the two screws ③.

8-8. Adjusting the Clearance between rotary hook and opener (Thread release finger)

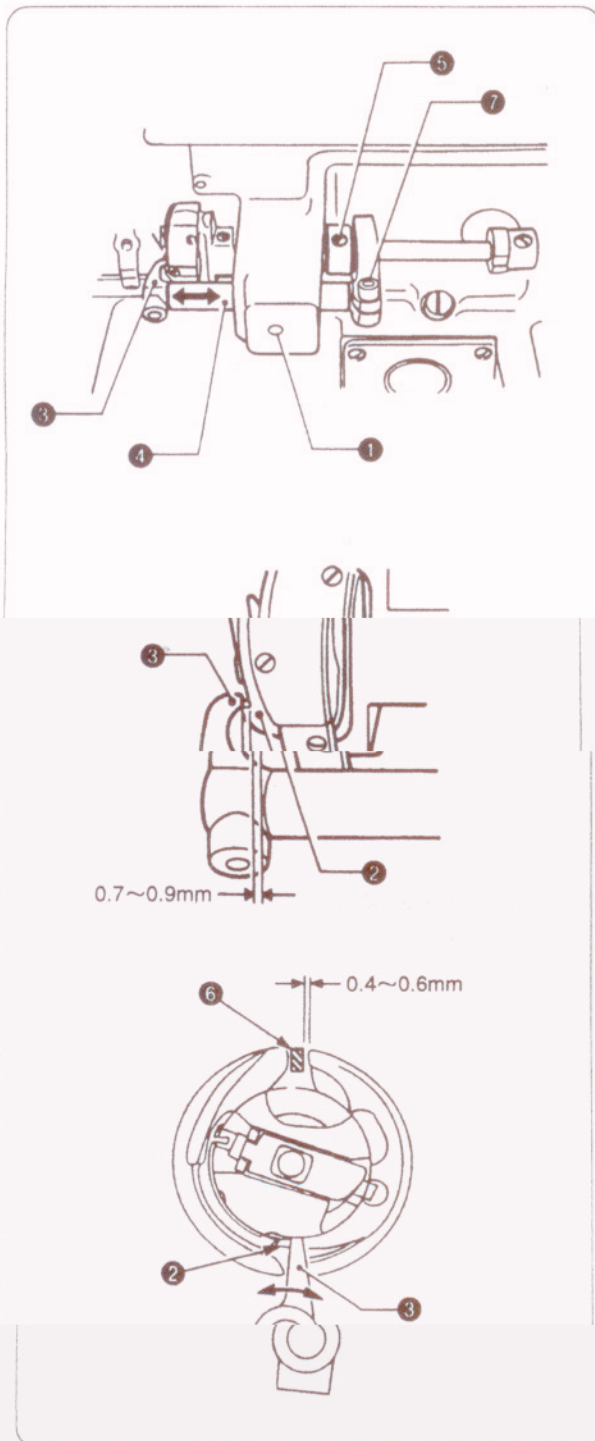

The opener facilitates the passage of the needle thread loop by slightly nudging the inner hook creating a slight rotating movement of it. This movement at that very instant opens a clearance gap between the notch of the inner hook and the tab of the hook retainer permitting the needle thread loop to be drawn easily through the gap.

■ Clearance between the opener and projection of hook.

1. Loosen the screw ①.
2. Adjust the clearance between projection of hook ②, and the opener ③ by means of movement of thread releasing shaft bushing ④ to the right or to the left as may be required. The standard clearance between the two parts is 0.7-0.9mm.
3. Tighten the screw ① securely.

■ Position of the opener cam:

Place the one of screws ⑤ which is indicated by "S" on V ditch of the hook shaft.

■ Adjustment of operation:

1. Turn the machine pulley until the opener ③ presses the projection of hook ② extremely on its travel.
2. Press the opener ③ to the projection of hook ② and make the right side clearance between the notch on the bobbin case holder and tab the hook retainer ⑥ 0.4-0.6mm. This adjustment can be done by loosening the screw ⑦.
3. Tighten the screw ⑦ securely.

8-9. Adjusting the clearance between feed forked connection and feed fork collar

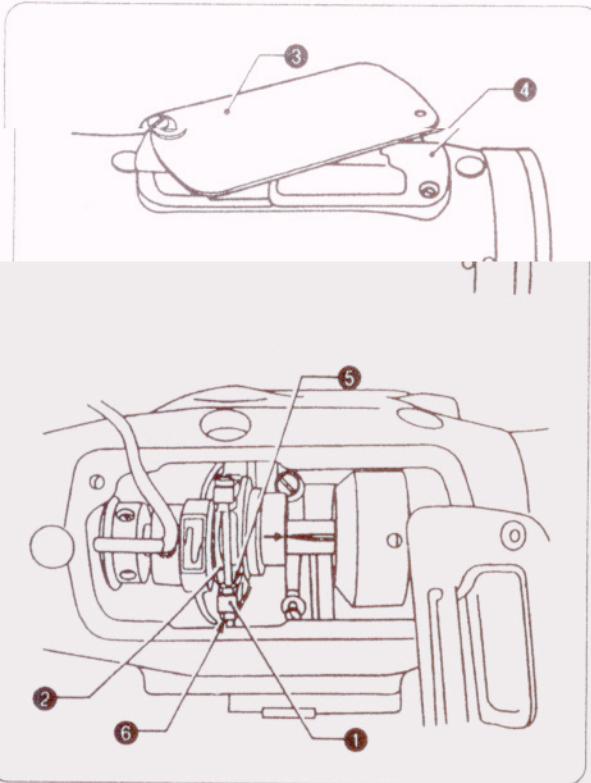

Incorrect clearance between the fork ① of feed forked connection and feed fork collar ② will bring irregular stitch length or overheating, etc.

1. Remove the cover plate ③ and the oil reservoir ④.
 2. To increase the clearance, loosen the nut ⑤ and turn the nut ⑥ to left or counter-clockwise.
- * This adjustment should be done with turning the machine pulley toward you to get correct clearance.
3. Upon completion of adjustment, tighten the screw ⑥ and screw ⑤.

8-10. Adjusting the height of the presser feet

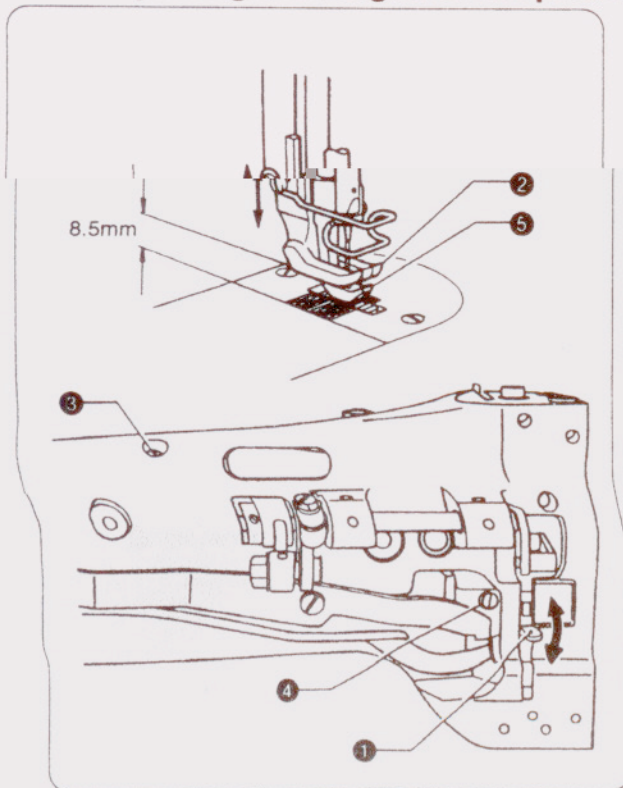

The standard height for the lifting presser foot ② is 8.5 mm when the presser foot has been raised by the presser bar lifter ①.

1. Loosen the screw ③, raise the presser bar lifter ①, and then loosen the set screw ④.
2. Move the lifting presser foot ② up or down to adjust its height.
3. Tighten the screw ④.
4. Tighten the screw ③ to adjust the presser foot pressure. (Refer to page 13.)

NOTE: If the height of the lifting presser foot ② is changed, the movement amount of the lifting presser foot ② and vibrating presser foot ⑤ will change. Adjust the amount of movement of the vibrating presser foot ⑤ so that it matches the movement of the lifting presser foot ②. (Refer to page 21.)

8-11. Adjusting the presser foot movement amount

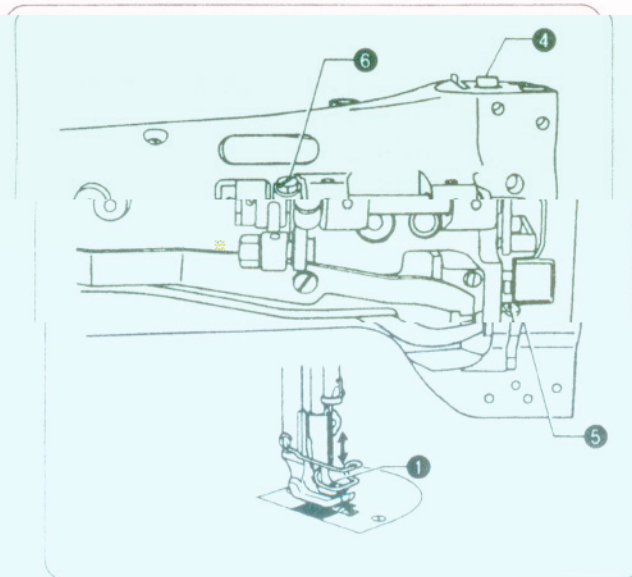
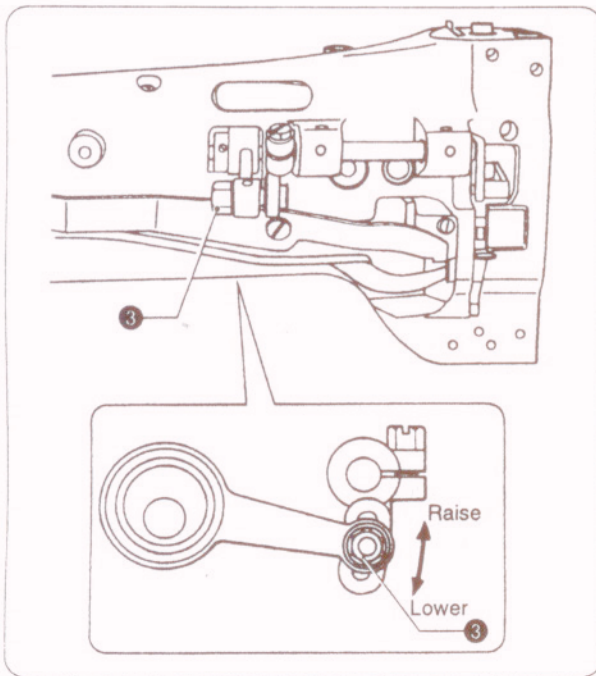
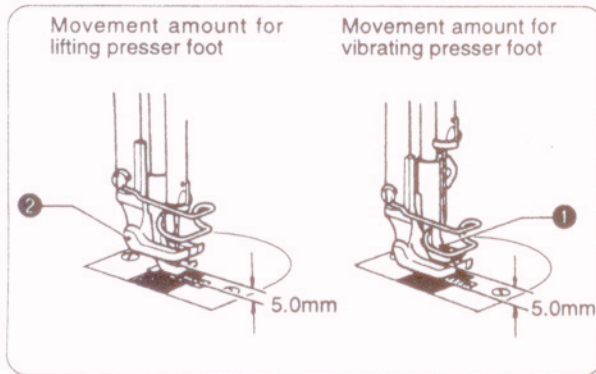

- Vibrating presser foot ① and lifting presser foot ② move up and down alternately.
- Normally, vibrating presser foot ① and lifting presser foot ② operate to the same height in their vertical motions.
- The maximum height of vibrating presser foot ① and lifting presser foot ② is 5.0 mm.

If changing the movement amounts of both the lifting presser foot and vibrating presser foot simultaneously, use method (A); if increasing the movement amount for only one (thereby decreasing the movement of the other), use method (B).

Method (A): Simultaneous adjustment of the movement amount for both the lifting presser foot and vibrating presser foot

1. Loosen nut ③.
2. Move nut ③ up or down as suitable to the work. (Raise the nut ③ for increasing motion; or lower it for decreasing motion.)
3. Tighten the nut ③.

Method (B): Adjustment of the movement amount for the vibrating presser foot

1. Loosen the vibrating presser bar screw ④ and lower the presser bar lifter ⑤.
2. While holding the vibrating presser foot ①, loosen the bolt ⑥ and then move the presser foot ① up or down as necessary.
3. After positioning the vibrating presser foot ①, tighten the bolt ⑥.
4. Tighten the vibrating presser bar screw ④.

8-12. Adjusting the timing of the vibrating presser foot

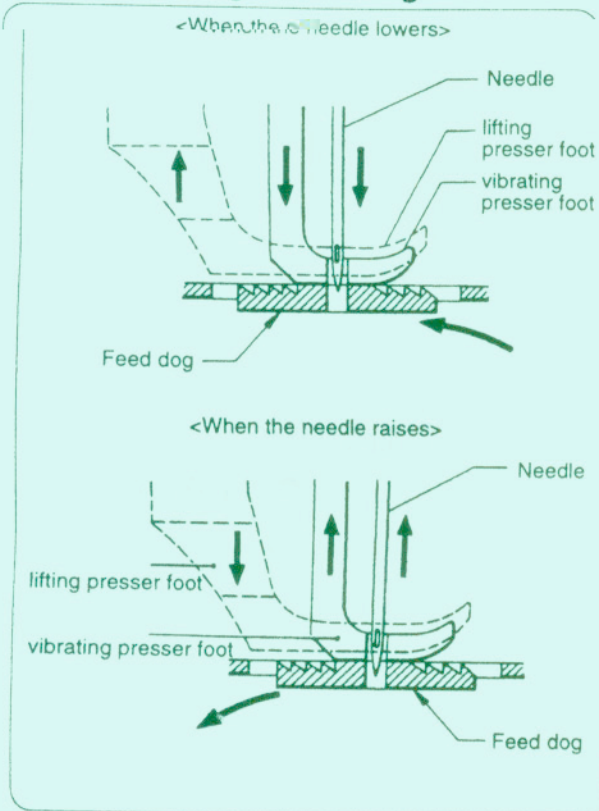

Correct the vibrating presser foot timing as follows:

1. Lower the presser bar lifter lever, then turn the pulley toward you. At this time, the vibrating presser foot should reach the feed dog before the needle eye does.
2. When the needle is raised, make sure the vibrating presser foot is still holding the material firmly. If the vibrating presser foot rises while the needle is still penetrating to the material, it may cause skipped stitches, etc.

If the timing is not correct after you make these adjustments:

1. Loosen the two screws ①.
2. To synchronize the timing of the vibrating presser foot, turn the cam ②.
3. Tighten the screws ①.

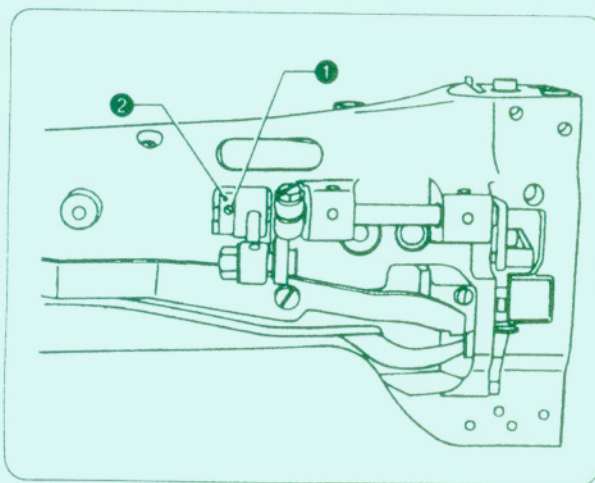

8-13. Adjusting the feed regulator



If the stitch length of forward and reverse is not same make adjustment of feed regulator.

1. Remove the arm rear cover plate ①
2. Turn the cover plate ②, loosen the screw ③ with holding upward the reverse lever.
3. When the mark of feed regulator ④ and feed regulator rod ⑤ are alignment, stitch length of forward and reverse will be same.
4. Turn feed regulator rod ⑤ to the arrow "X", stitch length of reverse is bigger and stitch length of forward is smaller.
5. Turn feed regulator rod ⑤ to the arrow "Y", stitch length of reverse is smaller and stitch length of forward is bigger.
6. After adjustment tighten the screw ③.

9. SAFETY CLUCH MECHANISM

If the thread is tangled with the rotary hook during sewing, the safety clutch mechanism for the safety clutch pulley operates to stop the lower shaft and let the safety clutch pulley race off load, thereby protecting the rotary hook and timing belt.

Release the safety clutch mechanism as mentioned below.

■ Releasing the safety clutch mechanism

⚠ CAUTION



- Turn off the power switch before releasing the safety clutch mechanism. The motor will keep turning even after the power is switched off as a result of the motor's inertia. Wait until the motor stops fully before starting work. The machine may operate if the treadle is pressed by mistake, which could result in injury.

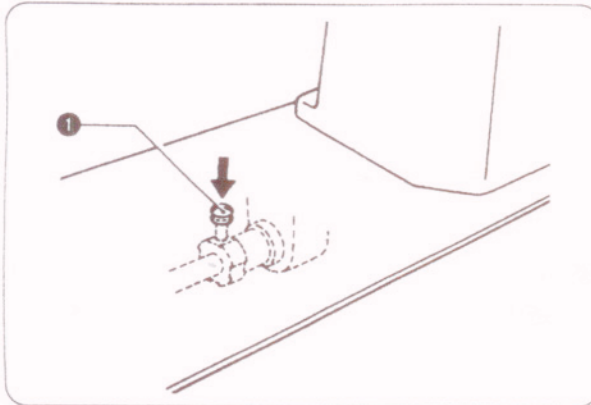

1. Remove the thread, etc. entangled with the rotary hook.

NOTE: Do not use a sharp-edged tool to clean the hook, as doing so may damage the hook.

2. Slowly turn the machine pulley while pressing push button 1 and the safety clutch mechanism returns to the original position.

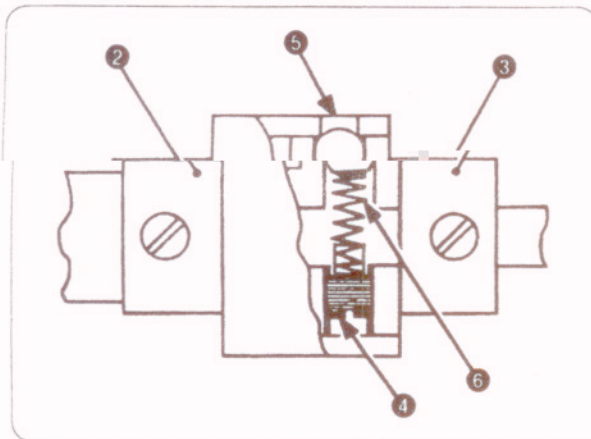

■ Adjustment of spring tension of safety clutch

If the safety clutch should become necessary to adjust spring tension, use the following procedure:

1. Depress the button 1 in the bed plate of the machine with your left hand. At the same time, turn the machine pulley strongly so that the safety clutch disengages.
2. Tilt back the machine head. Hold the safety clutch (left) 2 and turn the safety clutch (right) 3 until you can see the screw 4 through the hole 5.
3. To strengthen the tension of spring 6, turn the screw 4 to the right, while to lighten the tension, turn the screw 4 to the left.
4. Upon completion of adjustment, depress the button 1. At the same time, turn the machine pulley until the safety clutch re-engages.